



RADIALL®

SOGIE DIVISION

SALES DRAWING

618 023 001

Edition : _____

Page

TITRE : SIZE 5 SOCKET COAX FOR RG 179 AND RG 187 CABLE
ENVIRONMENTAL

SERIE : MPX

PEN : _____

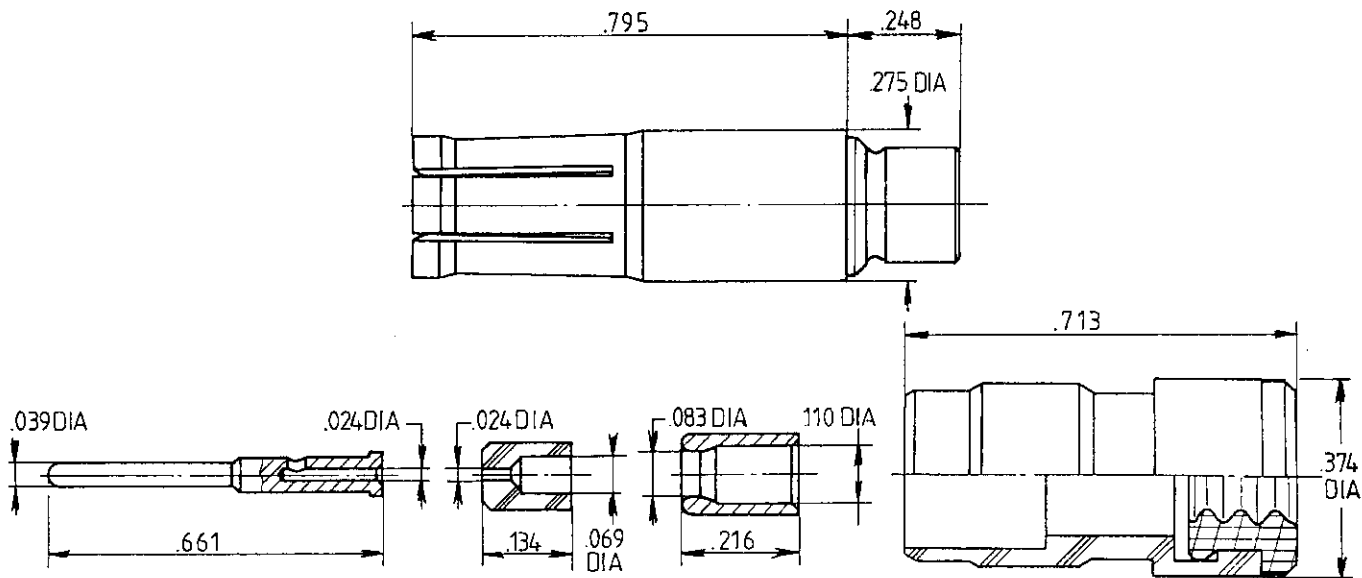

WIRING INSTRUCTIONS

- _ SLIDE SEALING BOOT OVER THE CABLE
- _ STRIP THE CABLE AS SHOWN
- _ SLIDE FERRULE OVER BRAID UNTIL IT BUTTS AGAINST SHEATH
COMB AND FOLD BRAID OVER FERRULE. CUT TO DIMENSION.
THEN STRIP DIELECTRIC TO DIMENSION SHOWN
- _ SLIDE INSULATOR OVER THE CENTER CONDUCTOR

_ INSERT CENTER CONDUCTOR INTO CENTER CONTACT SUB ASSEMBLY. CRIMP CENTER CONTACT USING TOOL M 22520/2_01 (RADIALL 282 281) SELECTOR N°7 POSITIONER DANIELS K 345 (RADIALL 282 550)

_ PUSH CABLE ASSEMBLY INTO BODY CONTACT CRIMP USING M 22520/5_01 (RADIALL 282 293) DIE: M 22520/5_05 (RADIALL 282 246) HEX. B

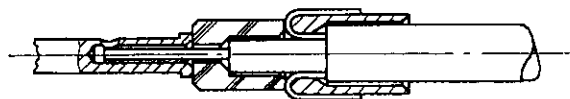
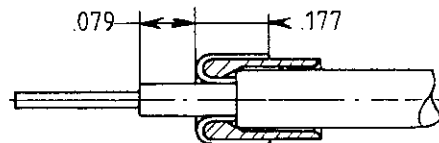
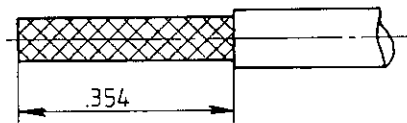

IND	MODIFICATIONS	DATE	VISA

Création Date 8-7-90

Mise à jour Date _____

Ces renseignements vous sont donnés à titre indicatif. Dans le but constant d'améliorer nos produits, nous nous réservons le droit d'apporter toutes modifications jugées utiles.



101, Rue Philibert Hoffmann - Z.I. Ouest
93116 ROSNY/S/BOIS Cedex (France)
Tél. : (1) 48 54 80 40 - Fax : (1) 48 54 80 35
Tél. : (1) 48 54 63 63
Télex : RADIA 235220